



**i-NOVATIVE** ©

beyond tomorrow

User Manual

# Factory-Link-SPE-G

## Industrial SPE 1000BASE-T1 Media Converter



INO\_Factory-Link-SPE-G\_User\_Manual\_V1.0.docx



## Table of Contents

Revision History .....	3
1 Introduction .....	4
2 Technical Data.....	4
2.1 Features.....	4
3 Scope of Delivery .....	5
4 Intended Purpose and Disclaimer.....	5
5 Connectors and Cables.....	5
5.1 1000BASE-T1 / 100BASE-T1 IEC 63171-6 Connector .....	5
5.1.1 T1-Plug Specification .....	5
5.1.2 Pin Assignment .....	5
5.1.3 T1 Cable Recommendation.....	6
5.2 Power Connector .....	6
5.2.1 Receptacle Specification.....	6
5.2.2 Pin Assignment .....	6
5.2.3 Power Cable Recommendation.....	6
6 Configuration.....	7
6.1 T1 Role (DIP1).....	7
6.2 Auto Role Switch (DIP2).....	7
6.3 Auto-Negotiation (DIP3).....	7
6.4 Speed (DIP4).....	8
6.5 1000BASE-T / 100BASE-TX Link.....	8
7 Software.....	9
7.1 Controller Functions .....	9
7.2 T1 Functions .....	10
Link Monitoring .....	10
Cable Diagnostics.....	10
Register Access.....	10
7.3 T(X) Functions .....	11
8 Important Information .....	12
8.1 Packaging Ordinance.....	12
8.2 Recycling Reference and RoHS Compliance .....	12
8.3 CE Marking .....	12
9 Manufacturer and Support.....	12
10 Warranty.....	12

## Revision History

Revision	Date	Change
1.0	09/03/2022	initial release version

# 1 Introduction

The Factory-Link-SPE-G connects 1000BASE-T1 with 1000BASE-T networks as well as 100BASE-T1 with 100BASE-TX networks. With an inductive T1 frontend, chassis grounding, and extra ESD protection of the network links, it is designed for industrial environments. The IEC 63171-6 compliant T1-connector makes it a plug-and-play solution for industrial Single Pair Ethernet. It supports 802.3bp auto-negotiation and proprietary master/slave detection. Master/slave role, speed and auto-negotiation modes can be set via DIP switches. The Control Center software connects via the USB-C interface to the Factory-Link-SPE-G and provides information about link state and signal quality and allows direct PHY register access. Faults in the T1 connection can be detected using the Signal Quality Indicator and the Cable Diagnostics function allowing shortcut, open connection, and fault distance detection. The Factory-Link-SPE-G is equipped with a dual power supply that seamlessly switches between the dedicated power port and USB. On the power connector, it supports a wide input voltage range from 5V to 28V. The housing can be grounded using either the power connector or the grounding screw.

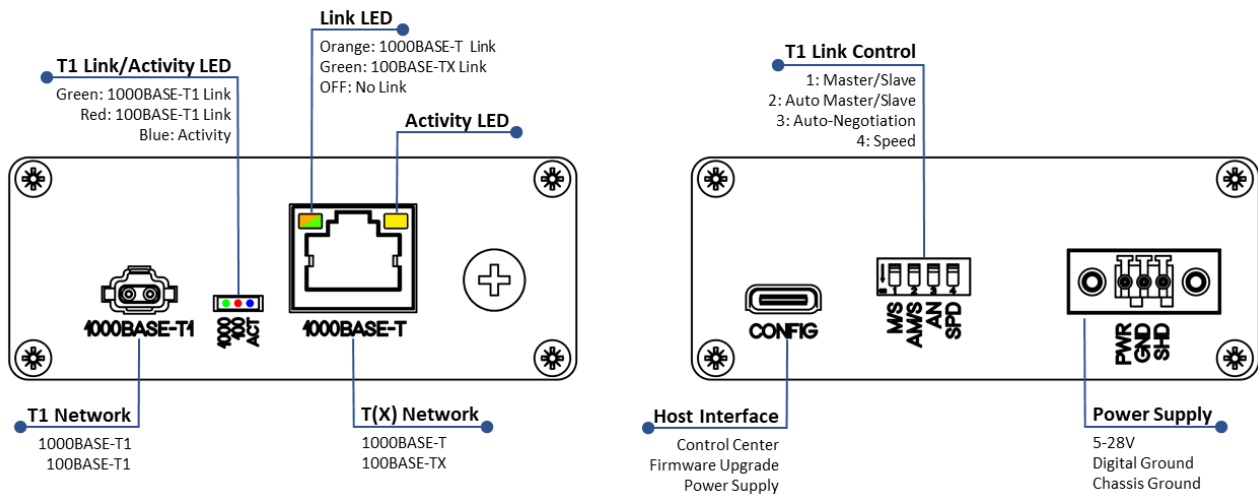

## 2 Technical Data

### 2.1 Features

- Standards: IEEE802.3bp, IEEE802.3bw, IEEE802.3ab, IEEE802.3u
- 1000BASE-T1 / 100BASE-T1 Port (T1 Industrial Jack AH IP20, IEC 63171-6 compliant)
- 1000BASE-T / 100BASE-TX Port (RJ45)
- USB-C Port (Control Center, Firmware Update, Power Supply)
- DIP Switch for Master/Slave, Speed, Auto-Negotiation Setting
- Automatic Master/Slave-Detection (proprietary)
- 802.3bp Auto-Negotiation
- 802.3bp Link Type-A (15m TP)
- Cable Diagnostics (T1 connection: open, short, fault distance)
- Aluminum Housing with grounding screw
  - Dimensions: 74 x 30 x 82 mm (width x height x depth)
- Power Supply
  - PWR Conn (3Pos Terminal Block): DC 5V – 28V
  - USB-C: DC 5V
  - Chassis grounding via Grounding Screw and/or SHD contact in PWR Conn
- Power Consumption: < 150mA @ 12V
- Environmental Temperature Range: -40°C - +65°C

- T1 ESD Protection
  - IEC 61000-4-2 (ESD) 25kV (Air), 25kV (Contact)
- TX Surge and ESD Protection
  - IEC 61000-4-2 (ESD)  $\pm 30$  kV (Air/Contact)
  - IEC 61000-4-5 (Lightning) 45 A (8/20  $\mu$ s)
- USB ESD Protection
  - IEC 61000-4-2 (ESD)  $\pm 15$  kV (Air) /  $\pm 8$  kV (Contact)
- Network Interfaces (PHYs)
  - 1000BASE-T1 / 100BASE-T1 PHY: Broadcom BCM89881
  - 1000BASE-T / 100BASE-TX PHY: Broadcom BCM54811

### 3 Scope of Delivery

- Factory-Link-SPE-G (Industrial SPE 100BASE-T1 Media Converter)
- Power Connector Receptacle (3Pos Terminal lock Plug)
- USB Cable (USB-A to USB-C)

### 4 Intended Purpose and Disclaimer

Disclaimer: The products sold by i-novative® GmbH are for development and testing purposes in automotive or industrial applications only. The product Factory-Link-SPE-G is not intended to be used in series application or series production.

Warranty Exclusion: i-novative® GmbH does not take over any liability for defects associated with the product and installation of that product. Our product warranty does not cover problems that result from abuse, accident, misuse, or problems with electrical power. It does not cover uses not in accordance with the instruction manual. It does not cover commercial use of the product.

### 5 Connectors and Cables

#### 5.1 1000BASE-T1 / 100BASE-T1 IEC 63171-6 Connector

##### 5.1.1 T1-Plug Specification

	Description	Vendor	Part Number
<b>Mating Plug</b>	T1 Industrial plug SL-C IP20	Harting	09 45 181 2810 XL
<b>Terminals</b>	T1 male crimp AWG 26-28	Harting	09 45 500 2810
	T1 male crimp AWG 22-24	Harting	09 45 500 2812

##### 5.1.2 Pin Assignment

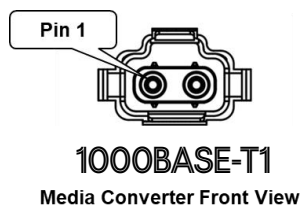

Pin	Signal	Remark
1	Data P	
2	Data N	
SHD	Shield	Connector Housing

### 5.1.3 T1 Cable Recommendation

For proper operation of the link, the used network cables and connectors for the T1 link must comply to the specifications of the respective standards. Please refer to:

- 100BASE-T1: “IEEE 802.3bw Clause 96.7”
- 1000BASE-T1: “IEEE 802.3bp Clause 97.6”

	Description	Manufacturer	Structure	Jacket	Shield	AWG
<b>1000BASE-T1</b>	T1 SPE IP20 1x2xAWG26/7 PUR 15m	Harting	2x0,13mm <sup>2</sup>	yes	yes	AWG26
	Dacar 676	Leoni	2x0,14mm <sup>2</sup>	yes	yes	AWG26
	Dacar 645	Leoni	2x0,17mm <sup>2</sup>	yes	yes	AWG25
	Dacar 646	Leoni	2x0,35mm <sup>2</sup>	yes	yes	AWG22
	FL09YBCY	Kromberg & Schubert	2x0,14mm <sup>2</sup>	yes	yes	AWG26
	FLCUSN9Y-9YBCY	Kromberg & Schubert	2x0,13mm <sup>2</sup>	yes	yes	AWG26
<b>100BASE-T1</b>	T1 SPE IP20 1x2xAWG26/7 PUR 15m	Harting	2x0,13mm <sup>2</sup>	yes	yes	AWG26
	Dacar 547	Leoni	2x0,13mm <sup>2</sup>	yes	no	AWG26
	Dacar 626	Leoni	2x0,14mm <sup>2</sup>	yes	no	AWG26
	Dacar 546	Leoni	2x0,35mm <sup>2</sup>	yes	no	AWG22
	Dacar 624	Leoni	2x0,35mm <sup>2</sup>	no	no	AWG22
	Dacar 617	Leoni	2x0,17mm <sup>2</sup>	no	no	AWG25
	FLR9Y-31Y	Kromberg & Schubert	2x0,35mm <sup>2</sup>	yes	no	AWG22
	FLKCuMgU9Y-9Y	Kromberg & Schubert	2x0,13mm <sup>2</sup>	yes	no	AWG26
	FLCUSNU9Y-31Y	Kromberg & Schubert	2x0,13mm <sup>2</sup>	yes	no	AWG26

## 5.2 Power Connector

### 5.2.1 Receptacle Specification

	Description	Vendor	Part Number	Distributor	Distributor Number
<b>Mating Plug</b>	3Pos Terminal Block Plug 2.5mm 180° free hanging	Würth Elektronik	691381030003	Digi-Key	732-6056-ND

### 5.2.2 Pin Assignment

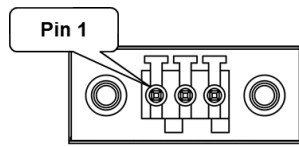

PWR  
GND  
SHD

Media Converter Rear View

Pin	Signal	Remark
1	PWR (+)	5V - 28V DC
2	GND (-)	
3	SHIELD	Chassis GND

### 5.2.3 Power Cable Recommendation

	Description	Manufacturer	Structure	Jacket	Shield	Remarks
<b>Power Supply</b>	FLRY 2x0,35-B RD/BL	Leoni	2x0,35mm <sup>2</sup>	no	no	AWG22
	FLRY-B 1x0,35 RD	Leoni	1x0,35mm <sup>2</sup>	no	no	AWG22
	FLRY-B 1x0,35 BL	Leoni	1x0,35mm <sup>2</sup>	no	no	AWG22

## 6 Configuration

Using the DIP switches, you can configure the master / slave role, speed and auto-negotiation modes of the T1 port.

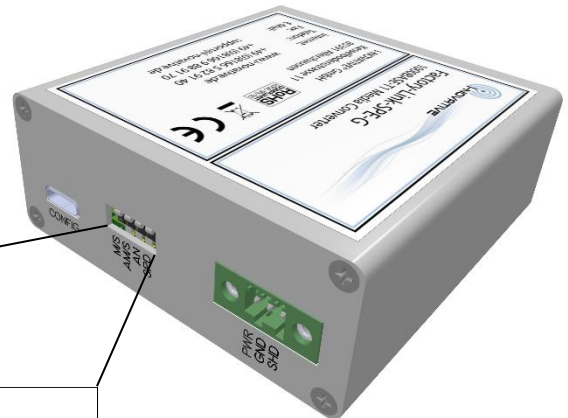

DIP Switch				
	1	2	3	4
<b>OFF</b>	Slave	Fixed Role	802.3bp Auto-Neg off	100BASE-T1 Mode
<b>ON</b>	Master	Auto Role	802.3bp Auto-Neg on	1000BASE-T1 Mode

### 6.1 T1 Role (DIP1)

DIP1 configures the T1 link role either to Master (ON) or Slave (OFF). If Auto Role Switch is active (DIP2=ON; DIP3=OFF) it has no effect. If Auto-Negotiation (DIP3) is turned on DIP1 controls the preferred role being advertised during auto-negotiation.

### 6.2 Auto Role Switch (DIP2)

DIP2 controls a proprietary Auto Role Switch function. When turned on, the Factory-Link-SPE-G automatically determines the T1 link role (master or slave). This function is for easily connecting to link partners not supporting 802.3bp Auto-Negotiation or having it turned off. This switch is ignored when Auto-Negotiation (DIP3) is turned on.

The Auto Role Switch feature can increase the link setup time.

Do not connect the T1 interfaces of two Factory-Link-SPE-G with activated Auto Role Switch on both sides. This may prevent the link establishment.

### 6.3 Auto-Negotiation (DIP3)

DIP3 turns the 802.3bp Auto-Negotiation feature on and off. When enabled, T1 link role (Master/Slave) and the link speed (1000/100Mbit/s) are automatically negotiated between the link partners. For proper operation, both link partners must support 802.3bp Auto-Negotiation and have it turned on.

When Auto-Negotiation is enabled at the Factory-Link-SPE-G, Auto Role Switch (DIP2) is turned off and DIP4 (Speed) controls the speed that is being advertised (OFF: 100Mbit/s; ON: 100Mbit/s and 1000Mbit/s). The effective link speed is determined between the link partners by the auto-negotiation protocol. The Auto-Negotiation Preferred Role is determined by the setting of DIP1.

## 6.4 Speed (DIP4)

DIP4 controls the link speed. If Auto-Negotiation (DIP3) is turned off, it directly sets the link speed to either 100Mbit/s (OFF) or 1000Mbit/s (ON). With activated Auto-Negotiation, DIP4 controls the advertised link speed (OFF: 100Mbit/s; ON: 100Mbit/s and 1000Mbit/s).

## 6.5 1000BASE-T / 100BASE-TX Link

At the “legacy” Ethernet side (RJ45 port), the Factory-Link-SPE-G is configured for Auto-Negotiation and follows the link speed of the T1 side. If the T1 link is established with 1000Mbit/s, the Factory-Link-SPE-G advertises 1000Mbit/s and if the T1 link is established with 100Mbit/s, the Factory-Link-SPE-G advertises 100Mbit/s.



## 7 Software

The graphical user interface is intended for remote monitoring. It can also be used for testing and development purposes since it provides direct access to the register sets of the integrated PHYs. It provides the following functions:

Controller	1000BASE-T1 100BASE-T1 connection	1000BSE-T 100BASE-TX connection
<ul style="list-style-type: none"> <li>• Media Converter Selection</li> <li>• Firmware Information</li> <li>• Device Reset</li> </ul>	<ul style="list-style-type: none"> <li>• Link Status Monitoring</li> <li>• Signal Quality Indicator (SQI) Monitoring</li> <li>• Cable Diagnostics</li> <li>• Read/Write Access to PHY registers</li> </ul>	<ul style="list-style-type: none"> <li>• Link Status Monitoring</li> <li>• Read/Write Access to PHY registers</li> </ul>

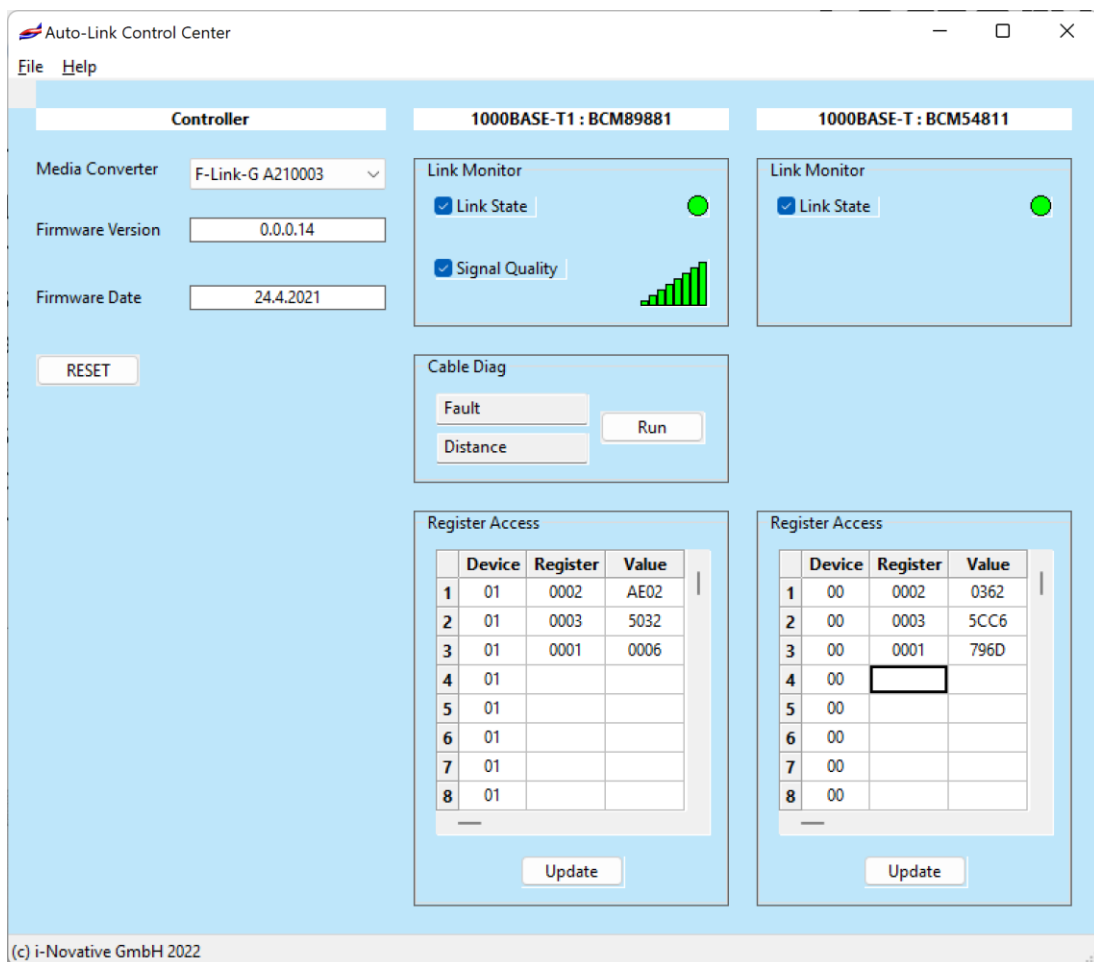

### 7.1 Controller Functions

If you have attached multiple i-novative® Media Converters to the same host via the USB configuration port, you can connect the UI to a specific one using the drop-down list. The Media Converters are distinguished by their type and USB serial number.

When an i-novative® Media Converter is selected, its firmware revision and firmware date are read out and displayed in the respective fields.

Using the RESET button, the Media Converter is re-initialized to its default state.

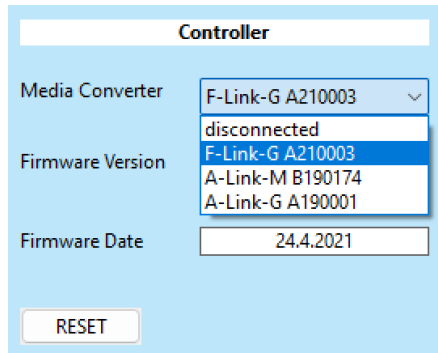

## 7.2 T1 Functions

### Link Monitoring

The UI provides continuous monitoring of T1 link state and SQI (Signal Quality Indicator). Using the checkboxes, you can enable and disable the respective functions.

The bars of the SQI bar-graph represent the exact SQI values ranging from SQI=0 to SQI=7. SQI needs to be 1 or higher for proper operation of the link.

### Cable Diagnostics

Using the T1 PHY Automotive Cable Diagnostics, cable faults and their distance from the device can be detected. During the measurement, the link is broken. The distance measurement has a tolerance of ±1.5m. ACD can detect broken wires (OPEN) and intra-pair shorts (SHORT). In case of an INVALID result, try to repeat the measurement. PAIR BUSY indicates traffic on the pair. Turn off the link partner in order to get a valid result.

### Register Access

The Register Table allows to read and write PHY registers directly. Modifying the register settings can impact the Media Converter functionality. All changes are transient and are lost after resetting or power cycling the device. Please use this function only if you do have the required knowledge. The software prevents write access to registers which can impact the hardware configuration. For a documentation of the PHY registers contact the PHY vendor.

The Register Table is laid out for Clause 45 MDIO access.

Device	Specifies the Clause 45 device address. The values are preconfigured and be selected by right-clicking a respective field.
Register	Is the PHY Register address according to Clause 45. Entering a value and pressing ENTER or TAB will read the respective register.
Value	Represents a PHY register value that has been read entering the address data in the Device and Register fields. Entering a value in this field will result in a write operation to the respective register. Written values are read back and displayed for a validation of the write operation.

All entries are expected to be hexadecimal numbers.

### 7.3 T(X) Functions

The “legacy” Ethernet PHY supports Link State Monitoring and Register Access like the T1 PHY. Please refer to the previous section for a description.

The used BCM54811 PHY does not support Clause 45 MDIO addressing. The Device address is used here to ease access to registers that need a specific access procedure.

00	1000BASE-T/100BASE-TX/10BASE-T Registers and Auxiliary Registers
18	Shadow 18 Registers: Enter the Shadow Selector in the Register field.
1C	Shadow 1C Registers: Enter the Shadow Selector in the Register field.
07	Clause 45 Registers
0D	Top Level Expansion Registers
0F	Expansion Registers

## 8 Important Information

### 8.1 Packaging Ordinance

„Basically, manufacturers as well as distributors are obliged to ensure that sales packaging are in principle taken back after use by the end user and recycled or reused.“ (according § 4 Satz 1 VerpackVO). If you as a customer have problems with the disposal of packaging and shipping materials, please write an email to [info@i-novative.de](mailto:info@i-novative.de).

### 8.2 Recycling Reference and RoHS Compliance



Please note that parts of the products from i-novative<sup>®</sup> GmbH must be properly recycled and must not be disposed with household waste (i.e. circuit boards, power supply, etc.).



i-novative<sup>®</sup> products are RoHS compliant (RoHS = Restriction of the use of certain hazardous substances; dt. „Restriction of use certain dangerous substances“).

### 8.3 CE Marking

The i-novative<sup>®</sup> Factory-Link-SPE-G has the CE mark.



This device complies with the requirements of EU Directive: 89/336 / EC Directive on electromagnetic compatibility and the mutual recognition of their conformity. Conformity with the o.a. directive is confirmed by the CE mark.

## 9 Manufacturer and Support

i-novative<sup>®</sup> is a registered trademark of i-novative<sup>®</sup> GmbH. If you have questions concerning our product, please contact us:

Manufacturer:	E-Mail:	<a href="mailto:support@i-novative.de">support@i-novative.de</a>
i-novative <sup>®</sup> GmbH	Phone:	+49 8166 5 82 91 40
Kesselbodenstrasse 11	Fax:	+49 8166 9 88 91 70
85391 Allershausen	Internet:	<a href="http://www.i-novative.de">www.i-novative.de</a>

## 10 Warranty

Within the warranty period, we eliminate manufacturing and material defects free of charge. For warranty issues please contact us via E-Mail: [support@i-novative.de](mailto:support@i-novative.de).